



DELE: a Deaf-centred E-Learning Environment

Paolo Bottoni*, Daniele Capuano, Maria De Marsico, Anna Labella, and Stefano Levialdi

Pictorial Computing Laboratory, Department of Computer Science, "Sapienza" University of Rome,
Via Salaria 113, 00198 Rome, Italy.

*Author for correspondence; e-mail: bottoni@di.uniroma1.it

Received: 15 July 2010

Accepted: 31 January 2011

ABSTRACT

We present a framework to address educational issues, especially focusing on deaf people, and present a preliminary model based on recent methodological findings. We started to develop multimedia learning environments based on Storytelling and Conceptual Metaphors, and adopt Cognitive Embodiment as a framework to address sensorially-critical subjects. We are using such methods to develop a Deaf-centered E-Learning Environment (DELE). Therefore, a Story Controller is designed for supporting stories handling. Its behaviour is formally specified through a formal model based on statecharts.

Keywords: storytelling, conceptual metaphor, cognitive embodiment, blending, sensorially-critical, e-learning.

1. INTRODUCTION

There is wide consensus that teaching effectiveness and student motivation are seriously challenged in the Internet era. On one hand, novel technologies allow to devise new teaching strategies, which may help to overcome the traditional limitations and difficulties of classroom teaching. As an example, learning material and its presentation can be effectively adapted to personal preferences/features of single learners. Motivation and individual learning style can be supported by structured approaches like multimedia storytelling. On the other hand, there is high risk of an improper use of technology, causing more disorientation than advantages, or to use it without fully exploiting its potential. There are many examples around of old-fashioned materials and processes

which are just trivially translated in a new electronic format. One of the issues to take into account is the gap between the traditional ways of presenting material in the classroom and the exposure to fast-paced presentations of information through the media. Such problems become specially relevant when addressing learners with critical sensorial abilities, as deaf people. It is worth noticing the scarce attention which is devoted to deafness problems in the web era, in contrast with a plenty of guidelines regarding for example blind people. Nevertheless, deaf people experience problems both with following oral presentations in the classroom and with access to media presentations based on verbal rather than visual or multimodal communication. According to many field

studies, this might be due to a different way of conceptualizing the reality and to map it on cognitive structures. Moreover, such structures do not find correspondence in the spoken language, and most of all in its representation (i.e. the corresponding written language). They are mainly multidimensional, and tightly bound to concrete experience. Scientific disciplines, with their frequent turn to completely abstract concepts, are one of the main challenges for both “normal” and impaired students. New terms, such as “innumeracy” (mathematical illiteracy), “math anxiety”, or “math phobia”, have been coined to describe students’ mood about mathematics [1,2]. In fact, one-third of all America’s incoming college freshmen enrol in a remedial reading, writing, or maths class [3]. In Italy, most teenagers have read no more than three books in their lives [4].

In a search for alternative ways of presentations, more able to engage students in interactive learning activities, we explore the potential of techniques based on metaphors and storytelling. These are expected to offer new and more participative approaches to the fruition of learning material. This should particularly hold for deaf students, for whom the mapping of a learning topic on a structured story, with its characters and “screenplay”, might better and more effectively support a peculiar cognitive style. We set an approach to metaphor-based teaching within a multimedia learning environment, which is organised along the notion of stories that can be told by students and teachers alike. To this end, we adopt the point of view of cognitive embodiment to situate learning within the bodily experience of deaf students. We further propose an abstract model of interaction with learning material as the exploration of stories, alternating individual and collaborative activities. The exploration, as well as the story flow, is not rigidly fixed and can be

personalized by the student, since the model “one size fits all” is particularly inappropriate in the context at hand. This means to also take into account the past development of the individual story exploration. Among other advantages, this allows to contextualize both revisited sections and newly entered ones according to the acquired cognitive fund of the single student. This appears to be one of the greatest advantages of the new technologies, as this kind of strong personalization would be very difficult, if not impossible, to achieve. This feature is always of paramount importance, but becomes absolutely necessary when learners with special needs are addressed.

Paper organization. Section 2 introduces relevant pedagogical ideas, while Section 3 defines the notion of “sensorial criticality” and its influence on the learning process of deaf students. The strategies and conceptual tools used for our teaching model are presented in Section 4. A Deaf-centered E-Learning Environment (DELE) is described in Section 5, while its Story Controller is detailed in Section 6. Section 7 closes the paper.

2. EDUCATIONAL MODELS

Historically, the Western teaching tradition seems to have followed a path moving from static-abstract to dynamic-concrete. Socratic maieutics is presented in Plato’s Symposium [5] and Theaetetus [6] dialogues. Knowledge is supposed to be already entirely present within the student as a forgotten and latent wisdom that all human beings possess. The teacher’s role is to help students to reach truth through dialogue, by helping them to remember the true knowledge. Hence the knowledge-building process, becomes a sort of rediscovery of something which is already known. On the other hand, Aristotle offers a different view, where an inductive approach for the knowledge-building process is argued

to occur, moving from particular to universal. Contrary to Plato's view, human beings are not supposed to have any latent knowledge to be simply remembered. Aristotle's approach influenced all the western philosophical and scientific traditions.

Much more recently, after a long period of education intended as mere mechanical transmission or positive conditioning, an increasingly student-centred, experimental-based teaching strategy has been proposed. In his novel called "Emile: or, On Education" [7], Jean-Jacques Rousseau describes a "natural" teaching approach, in which a tutor guides the student through several learning experiences, so that children can tell right from wrong by experiencing the consequences of their acts. Jean Piaget's *constructivist* learning theory provides a general theoretical framework about psychological aspects of the learning process [8]. In his view, the learner's direct experience within the environment is the first tool to be used to build a cognitive model of the world, strongly emphasizing the importance of the learner's active involvement in the learning process. The student carries out the learning process by interacting and collaborating, rather than by passively listening to a lesson, and the teacher is a facilitator, helping students to reach their own understanding of concepts.

Also the psychologist Lev Vygotsky has a similar consideration of the teacher's role [9]. He coins the term "Zone of proximal development" to express the range of concepts that are too difficult for the student to confront them alone, but that can be understood with the help of a teacher. Thus the teacher has to provide the right learning setting for the student to autonomously reach the learning goals. Moreover, Vygotsky stresses the relevance of the social and cultural context in the whole learning activity, as well as in the study of the psychological processes of

learning. It is impossible for him, unlike Piaget, to achieve an universal theory of the learning development stages, since every individual is not separable from the context in which he or she lives.

Finally, Bruner's cognitive learning theory is particularly related to our approach. In [10], he claims that our mental representation of reality is structured by means of cultural products such as language and other symbolic systems. One of the most important is narrative. For Bruner, "we organize our experience and our memory of human happenings mainly in the form of narrative – stories, excuses, myths, reasons for doing and not doing, and so on" [10], .

3. SENSORIAL CRITICALITY, DEAFNESS AND LEARNING

As stated by Vygotsky, learning contexts are fundamental in the teaching process design. Sensorial criticalities are an undermining factor within them. With "sensorial criticality", we refer here to the lack of some sensorial reference experienced by students within the learning process. Therefore, the presentation of totally abstract concepts, in specific cases, as well as a physical disability or a more general hindering factor, can entail severe learning problems. For example, mathematics can be seen as a sensorially critical discipline, since it seemingly lacks of concrete, sense-related concepts. This paper is mainly concerned with the physical kind of criticality, even though examples of the other one are also provided. In particular, we focus on deafness as a learning-critical disability.

Deafness is a very hidden handicap, since most people simply don't know anything about the communication-related problems that deaf people do experience. In fact, due to their hearing disability, all deaf people meet dramatic difficulties in acquiring both written and vocal language skills, so that many social

communication problems arise. Deaf are essentially visual people, primarily using the visual channel both for grasping informations and for communicating with others. Even though reading and writing can be regarded as visually supported activities as well, they are indeed sequential processes. This characteristic is deeply connected with the serialisation of communication which is peculiar of traditional aural-based experience of language. On the other hand, deaf interpretation and transmission of (visual) information seems to be basically multidimensional, with a prevalence of synchronous constructions. This can be especially observed in Sign Languages (SLs), visual-gestural language used by most deaf people. When exploited, the national sign language is a very important resource to be used in classrooms, since it can help to overcome some comprehension difficulties. Specialized professional figures are sometimes provided by schools, giving communication assistance for some difficult parts of the lesson to be translated in sign language. However, several deaf persons, due to socio-cultural constraints and prejudices, do not use their national sign language and communicate via spoken and written language. Lip-reading and speech therapy techniques are in this case used as a support. Nevertheless, these persons do experience difficulties with their literacy skills anyway. In particular, it is worth noticing that both signing and non-signing deaf make similar mistakes with spoken and written language [11]. Therefore, a deaf-peculiar common approach to spoken/written language might be supposed. Moreover, due to the above underlined sequential/simultaneous opposition in communication structures, it is often difficult to provide an accurate sign language translation of text and spoken materials, and vice versa. As a matter of fact, it is widely accepted in most research lines that SLs extensively use complex signs,

defined as Highly Iconic Structures [11], which go well beyond the usual single words in a vocabulary. These provide information in a multilinear, simultaneous fashion without parallel in spoken/written language. Due to the mentioned issues, the learning process is quite problematic for deaf students. In order to design a teaching method addressing the whole deaf community, both signing and not-signing, a more comprehensive strategy has to be devised. We argue for a visual, bodily-based interactive teaching approach, exploiting the peculiar way of communicating and understanding concepts by deaf people. Storytelling and computer-aided metaphors are presented in this paper as the main tools for implementing such an approach.

4. CONCEPTUAL TOOLS AND STRATEGIES

In the following subsections we describe the main concepts influencing the creation of the proposed teaching model and the derived support architecture.

4.1 Storytelling, Learning and Multimedia

For Bruner, narrative operates as a mind's tool in interpreting reality [10]. Storytelling is a pervasive way of modelling experience. We live within stories and we see ourselves as the main characters of our own lives. Stories help us to give a personal interpretation of events. Moreover, storytelling is apt to implement a constructivist learning methodology [12]: students trying to construct stories must carefully design their goals, have to make sense of their experiences, and must deeply reflect on their understanding. Afterwards, storytelling allows them to share a reflection on the results of this meta-cognitive process with others.

Along the above line, the storytelling-based model by McDrury and Alterio organizes the educational activity into five steps [13]. Stories have, first, to be devised by

students and, second, to be told. Hence, students need to organize their own thoughts and establish their narrative goals. The third and fourth steps are story “expansion” and “processing”. Additional insight is reached through dialogue, i.e. by seeing the story from different points of view or comparing it with similar ones. Finally, the teacher evaluates such stories, showing students some alternative practices that could have been used.

From the mid-1990s the use of multimedia technology as a storytelling tool has been increasingly exploited for educational, artistic and general communicative purposes. People started developing their own brief multimedia movies, using some software tool, and telling stories about many different subjects. Recent advances in multimedia technologies and their increasing diffusion, lend themselves to be of special interest within the above teaching/learning perspective. As an example, the increasing appeal that storytelling is inspiring to the educational and psychological research community is shown by the Digital Storytelling project [14-16]. Due to the great emotional impact that can be offered and the expressive possibilities allowed, multimedia-aided storytelling is going to be more and more used at school, where it may represent a motivational improvement for both students and teachers, and provide a more attractive experience of learning [16]. Classroom lessons could be enriched by means of students’ or teachers’ stories, thus increasing the student’s direct involvement. More in general, in some learning domains, the storytelling approach can be particularly powerful. For instance, it offers several interesting applications for teaching Human-Computer Interaction and Software Engineering [17], where stories are both the mean and the object of teaching. First, concerning the system design process, storytelling enables a bottom-up approach in

presenting the design of a new system. Within the engineering storyboard, target user stories are collected and analyzed at the very beginning of the design (requirements finding). Such stories have to be rich of details, e.g including the names of the users and their general habits within the use-cases contexts. Thus, designers’ efforts are aimed at creating a story by focusing on the real needs of the users. Going further along this line, in presenting an Object Oriented system, every object can be seen as an agent living its own business story. As Imaz and Benyon said, “during their travels, the objects will encounter other objects, which they will interact with. Each interaction will be compressed as an operation and eventually implemented as a method into the appropriate part of the class construct” [17]. Figure 1 shows a representation of such idea, where objects are agentified and interact in a virtual environment.

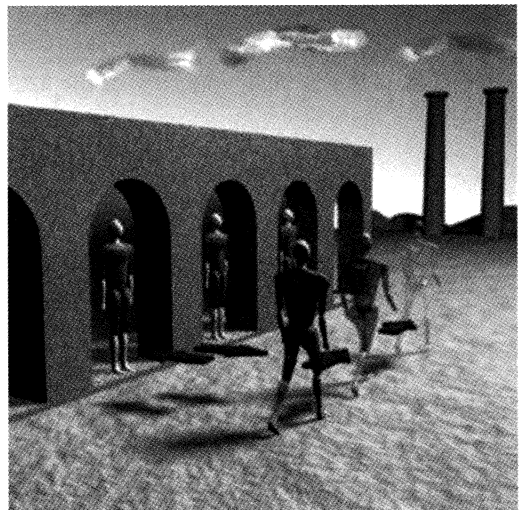

Figure 1. A representation objects as agents living their own, possibly interlaced stories [17].

In this scenario, instantiating a class means letting the class-agent’s story to be started. The advantage of using such an approach is twofold: from the design perspective, a more natural way of thinking can be used, helping the designer to maintain a more organic and

holistic view of the system; from the analysis perspective, stories can be searched for within all the system documentation. For example, a class diagram could be seen as a particular view of the system's story, showing it as a sort of "society" of interacting people. This point of view can make the system analysis easier and nearer to the human level.

Finally, from the human-computer interaction point of view, an interactive computer system has to "tell a good story that engages the imagination" [17], and this especially holds in educational electronic environments. The learners' motivation and involvement could be improved by implementing such a "good story". This corresponds to providing an intuitive and comfortable environment where the users' actions have to be performed and a suitable mapping of the learning domain concepts can be implemented. Designing such appealing interaction entails a deeper understanding of one of the most important tools we aim to use: metaphor, which is one of the main concerns of the next sections.

4.2 Cognitive Embodiment and Metaphor

We embed storytelling into the more general framework of Cognitive Embodiment (CE), for which all knowledge stems from the body [18-21] and fundamental bodily-based Image Schemata, e.g. link, force, containment, balance, path, are built via body-mediated experiences. Other cognitive functions project this bodily, image-schematic knowledge onto conceptual and abstract domains. A further powerful tool is the Conceptual Metaphor.

The Conceptual Metaphor (CM) establishes a mapping between two domains, usually a concrete, body-related domain and a more abstract one. Examples of CMs are found almost everywhere. Every human language uses CMs to communicate meanings at

different levels of complexity. For example, in the worldwide used metaphor "Love Is a Journey" [18], we use sentences like: we are driving too fast, we are at a crossroad, our relationship has hit a dead-end, etc, using the mapping from lovers to travellers, from love relationship to vehicle, from lovers' goals to travel destinations, and from relationship difficulties to travel impediments. In general, a CM is a way of understanding situations and concepts. In [21] four metaphors are proposed for the arithmetical domain, viz: Arithmetic as an Object Collection, as an Object Construction, as a Measuring Stick, and as Motion Along a Path. To better understand the entailments of changing the reference grounding metaphor, let us compare two of the above arithmetic metaphors: Arithmetic as Object Collection and Arithmetic as Motion Along a Path, with the following mapping [21]:

Arithmetic as Object Collection

- Collections of objects of the same size → Numbers;
- The size of the collection → The size of the number;
- Bigger → Greater;
- Smaller → Less;
- The smallest collection → The unit;
- Putting collections together → Addition;
- Taking a smaller collection from a larger collection → Subtraction

Arithmetic as Moving Along a Path

- Acts of moving along a path → Arithmetic operations;
- A point-location on the path → The result of an arithmetic operation;
- The origin, the beginning of the path → Zero;
- Point-locations on a path → Numbers;
- The unit location, a point location distinct from the origin → One;

- Further from the origin than → Greater than;
- Closer to the origin than → Less than;
- Moving from a point-location A away from the origin, a distance that is the same as the distance from the origin to a point-location B → Addition of B to A;
- Moving toward the origin from A, a distance that is the same as the distance from the origin to B → subtraction of B from A.

Other operations, like multiplication and division, can be obtained from these base mappings. The first worth noting thing is the presence of a natural element that maps the Zero in the Arithmetic as Motion Along a Path metaphor, while such a natural mapping cannot be found in the first metaphor. In fact, thinking of the Zero element as a collection is not so obvious, because it implies accepting that a collection with no elements is a collection at all. Actually, such an operation is a metaphor itself. A further fundamental difference is that the “moving along a path” metaphor allows one to imagine moving away from the origin in both directions of the path, thus obtaining negative numbers. The set of negative numbers cannot be obtained by using the Arithmetic as Object Collection metaphor. We can conclude that our way of thinking is constrained by the metaphor we use.

Another example of CM is found in the different ways of writing music, where reference to the body movement is always present.

Recent studies with neuron-imaging techniques prove that CMs are not arbitrary [22], as metaphors activate coherent sensorimotor neural circuits. For example, hearing “he handed me the theory” activates the brain regions connected to hands movement.

CM goes beyond concept transmission, and has been proposed in HCI as a source of guidance for inclusive design [23]. Since metaphor is a subconscious mental represen-

tation used to understand concepts, it has been supposed to be an almost universal presentation tool, despite the different levels of cognitive ability and experience with technology that people do have. An experiment has been conducted using 12 “primary metaphors”, i.e. metaphors that map sensorimotor, image-schematic base patterns into abstract domains (e.g. the MORE IS UP – LESS IS DOWN metaphor). Such metaphors were chosen among the 250 that have been documented in literature [24, 25]. One image-schematic spatial dimension has been presented to the participants together with a target phrase for an abstract concept. Participants were asked to perform free arm gestures on the given spatial dimension to represent the target phrase. For example, the UP-DOWN image-schematic spatial dimension has been proposed together with the “powerful, powerless” target phrase. Participants could perform any arm gesture on the UP-DOWN dimension to represent the “powerful, powerless” phrase (e.g. moving the arm up to represent “powerful” and down to represent “powerless”). In this case, the connection between the performed gestures and the primary metaphor POWER IS UP – POWERLESS IS DOWN [25] can be tested. The results show that in 92% of all cases users choose gestures that confirmed the documented metaphors. Thus CMs can be employed in interactive computer systems to achieve intuitive and familiar interfaces also for educational purposes. This is extensively explained in the next section.

4.3 Conceptual Blend and HCI

The cognitive process defined by the Conceptual Blend allows one to build a new conceptual domain from two existing ones. As shown in Figure 2, a Conceptual Metaphor can provide the two input domains, where the third domain represents a synthesis and

an implementation of the metaphor itself. Such a new domain is composed by using the inferential structure of either one or both of the two input domains, and it also reveals a new emergent structure. Computer Science and, in particular, Human-Computer Interaction are fundamentally built via Conceptual Blends [17]. In fact, graphic interfaces as well as old-style consoles, windows, widgets and all interaction paradigms are implementations of hidden metaphors: in other words, Conceptual Blends.

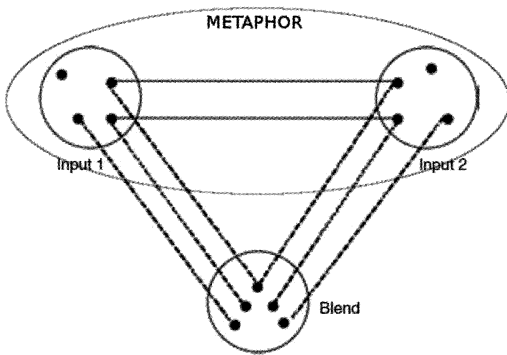

Figure 2. A Conceptual Blend schematic.

Computer Desktop is perhaps the most remarkable and known example. It takes its input domains from the Computer as an Office metaphor (see Figure 3).

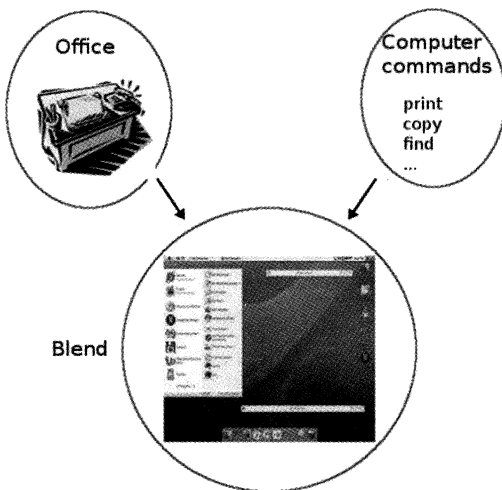

Figure 3. The Desktop Blend.

The Office domain provides the well-known inferential environment, while the Computer-commands domain should be hidden to the end users. In fact, only the Office structure (i.e. the general appearance of the environment and some basic interaction paradigms) is projected into the blend, to exploit user’s familiarity with such an environment. Computer commands are only provided through the interface but are not explicitly shown. As in a real office, users can find common objects that they can interact with, such as documents, folders, a trashcan, and computer commands are executed through the interactions with such elements. Nevertheless, several differences with respect to a real office environment can be found too. Due mainly to the bidimensional perspective of this blend, a new structure emerges, concerning topological, spatial and interaction issues.

4.4 Story-centered Educational Tools

So far, we have addressed issues concerning learning and computer systems: storytelling is one of the most powerful tools to be used in a learning environment, and it can be seen as a very pervasive metaphor in our experience. Metaphors can in their turn implement stories, providing the story’s structural details and “embodiedness”. As a further conceptual step, the Conceptual Blend in HCI is the concrete implementation of a story via a grounding metaphor. We can say that every human language provides its own stories and, while stories are usually built up through Conceptual Metaphors, the Metaphor itself cannot be implemented without a Conceptual Blend. Such a blending process creates a sort of “conceptual artefact” that substantiates the metaphor, hence the story it describes. Thus, for an interactive system to “tell a good story” it has to use a good metaphor. Also the Apple Human Interface Guidelines [26] argue that

“Metaphors are the building blocks in the user’s mental model of a task”, suggesting to use metaphors as a starting place in the human interface design.

How can we exploit the above concepts to give an answer to the crisis and to current issues on learning? Present-day teaching methods are primarily implemented by means of classroom blackboard-aided lessons and standard learning materials (e.g. books, slides, etc.), while audits are provided basically through oral and written standardized tests. Such an approach can be experienced as quite difficult, especially for abstraction-based disciplines, like mathematics, where concrete reference points could be hard to find by students. As stated above, stories represent one of our most important conceptualization tools, since detailed and human-level descriptions are provided by them. Human-level, rich-of-details descriptions have always to be provided as a fundamental part of lessons. In fact, even the use of simple image-schematic representations alone, e.g. instances of containers for sets in a sets-based mathematical explanation process, could lead to hard-to-understand concepts. This is due to the quite abstract context in which such image-schematic representation is presented. This kind of problems can be compounded by having story-based descriptions as a structural aspect of lessons, thus facilitating the students’ conceptualization process.

Multimodal interactive computer systems can play a very important role in this approach. In fact, graphic visualizations can enhance the story vividness and attractiveness, while task-oriented interactive environments can improve students’ involvement, giving a non-mediation illusion in which the user seems to “live” the learning process. Virtual graphical environments, augmented reality, multimodal and multisensory interaction strategies are best examples of technologies to be used. An

e-learning environment exploiting virtual graphic spaces (Virtual Worlds) in Second Life is presented in [27]. Virtual Worlds focus on collaboration in social networks, without reference to Storytelling or CM. While many static graphic representations of knowledge (e.g. storyboards, charts, diagrams, etc.) can be provided even without using computer systems, their interactive and animated versions can be implemented only with suitable software systems, but they could yield great motivational improvements. Virtual environments can also visually include metaphors and stories: storytelling has a natural visual representation as a motion along a path. Providing such a path to be explicitly visualized can enhance the students’ feeling of continuity of the learning process. Furthermore, seeing himself or herself physically moving – within the virtual environment – along such path, can increase the students’ motivation and involvement.

4.5 A Story-Centered Educational Model

The reflection on the issues and concepts presented above has driven the specification of the proposed teaching model, especially devised for sensorially-critical subjects. It implements a constructivist-like, metaphor-based and story-centred approach supported by multimedia and multimodal computer systems. Students’ involvement and learning thread maintenance are targeted by using storytelling as a general approach, while motivation and user friendliness can be provided by designing task-specific metaphors.

Figure 4 shows a schematic view of the model, which is entirely based on the functional coupling of the metaphor tool with the storytelling strategy. A main metaphor implements the main story of the learning module. Each Learning Unit (labelled LU in Figure 4) is further represented as a metaphor-

story coupling in itself. In fact, containment and path image schemata provide the whole model structure, i.e. metaphor-story couplings are arranged in through recursive containment. Each story maintains the path to be followed through its units, and presents it in an easy and recognizable fashion, while supporting many possible alternative paths in order to respond to each student's needs. Different metaphors allow both context-specific graphical presentations and task-oriented interaction strategies to be offered, while embodiment principles are always taken into account. Learning Units should contain both Story-based Learning Activities (SLA) and audits.

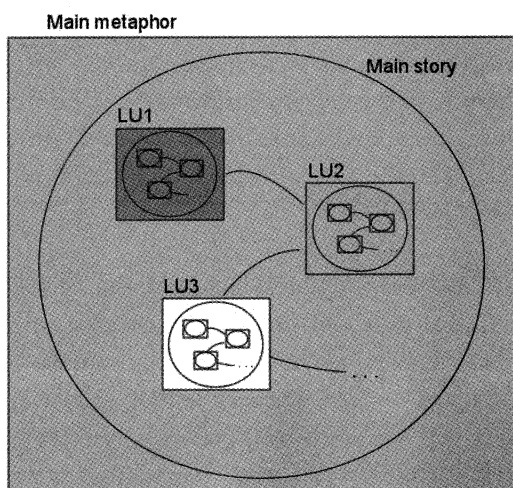

Figure 4. A schematic view of our model.

Such a model can be considered as an implementation of an e-learning approach in its broadest sense. It could be seen as a computer-aided teaching method to be exploited within classroom as well as in distance learning, or in a blending of both. The teacher can design the stories and metaphors to be used, encouraging communication among students through face-to-face dialogue as well as by means of electronic media (textual chat, video chat, messages, etc.) and letting the students themselves develop their own multimedia-based stories.

Collaboration is another important issue to consider. Stories should provide a social environment in which students can collaborate by communicating with each other (e.g. asking for help on something that has not been understood) as well as by working together for some task to be accomplished. The students' story design can therefore be also used as a collaboration tool in order to enhance discussion and problem solving in group.

Finally, both student's storytelling strategies and audit results can be evaluated to assess and improve students' story interpretation and design practices, providing new perspectives and developments.

5. THE DELE SYSTEM

The model presented in the preceding section is being exploited in the Italian project VISEL [11], aimed at designing a Deaf-centred E-Learning Environment (DELE). Due to the deaf literacy problems discussed here, designing a DELE is a challenging task. Moreover, accessibility guidelines for deaf people are only sketched in [11], providing only some fairly general indications about the importance of using sign language videos, video conferencing and tools equipped with signing avatars. Most existing e-learning environments designed for deaf people provide them accessibility only by means of SL videos, to be shown near the textual materials. Nevertheless, we have underlined above that such a feature does not help the whole deaf community, which also includes non-signing people. In order to address these issues, we are designing a story-based DELE that provides an immersive graphic environment based on metaphoric constructions, where the use of text-based materials is limited whenever possible.

5.1 DELE System Model

Figure 5 shows the main top-story told by the DELE as an instance of the general model above. The underlying system itself is presented through a story. Users are accompanied to choose the system settings before the actual learning process starts: for example, they can set their personal details (e.g. name, avatar, etc.) through the “User settings” sub-story, they can choose some general graphical settings (e.g. colours, fonts, etc.) by entering the “Appearance settings” sub-story. After setting preferences, the users are projected on the true learning story.

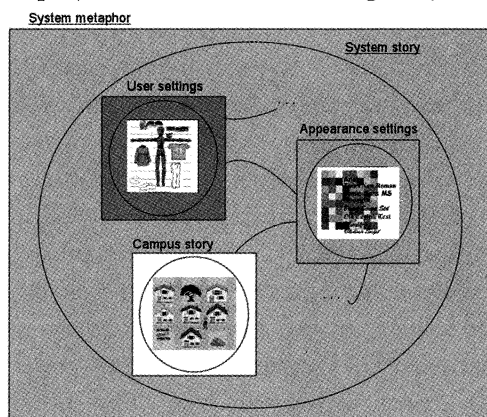

Figure 5. A schematic view of DELE.

Since the project’s target population is High School and University students and young deaf professionals, the story develops within a university campus metaphor (Figure 6). Here the “campus” refers both to the metaphor employed for the system and to the virtual graphic environment in which the stories of each user develop. Entering the campus, a virtual avatar is provided for the user to explore the graphical environment. Thus, deaf people’s peculiar visual-bodily way of grasping information can be exploited.

Information browsing is not arranged in a textual/tabular fashion, but the user is asked to move within the various sub-environments (i.e. sub-stories) to accomplish several learning tasks.

The main goal of the campus environment is to enrich the entire society by means of knowledge. No challenges or competitions among users are allowed; they are rather asked to share the knowledge they acquire, since a greater virtual-society wellness can only be achieved in this way. Each learning unit engages the user in several vocal/written language comprehension and production activities, since the general competence improvement on a specific discipline is the final goal of each learning unit. The user can meet other users and they can engage together for communication and collaboration activities. Communication will be fostered through several different codes: written language, sign language and written sign language. The latter will be encoded in SignWriting, an experimental coding resource which is increasingly used by the deaf community due to its ease of use. In fact, while many formal representations of sign languages have been provided by worldwide research, such languages do not have an official written form yet. SignWriting seems to be a promising encoding, since all the information conveyed into sign languages (i.e. hands motion and configuration, facial expression, body postures, etc.) can be naturally represented through it.

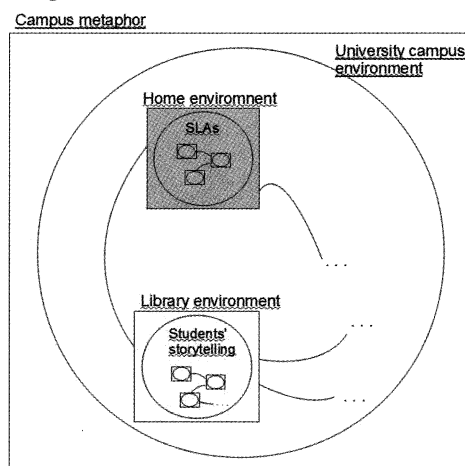

Figure 6. A schematic view of the campus story.

The Home Environment provides the base learning place. It implements a sub-story where several learning materials can be found. By selecting one of them, the user is projected into the corresponding sub-story implementing the SLA for the related argument. SLAs will be designed in order to “facilitate” textual material, providing iconic as well as animated resources to enrich some difficult parts of the text. Text authenticity/semantics is not changed, but additional materials are provided to facilitate/support the mental processes that vocal/written language entails by complementing it with bodily-rooted elements.

Finally, the University Environment is another example of sub-story that will be implemented. Here, students can share their knowledge with the entire campus community, receiving credits for this. Following the Digital Storytelling lesson, students’ own multimedia stories could be developed and presented, thus exploiting the pedagogical benefits of storytelling.

The presented environments are just a few examples of what can be provided by DELE. As stated in [28], it is important to

involve impaired people directly in the design process in order to achieve learner-centred e-learning environments. Along this line, in our case several deaf researchers have been actively involved both in the design phase and in the successive prototypes evaluation. We think that such an approach will ensure that the actual needs of deaf people will be taken into account, and that appealing and intuitive metaphors will be designed.

DELE design entails many interaction issues. Since only the visual channel can be used by deaf people both to transmit and receive information, a forced mono-modality seems to be needed. For example, in a typical classroom-based lesson students can listen to the lesson and write down notes, or the teacher can speak while they are looking at the blackboard. When deaf students are involved, such interaction patterns are impossible, since all information must be conveyed through the only visual channel. Moreover, if the teacher looks at the blackboard, no spoken word can be grasped by means of lip-reading. The DELE interaction model is shown in Figure 7.

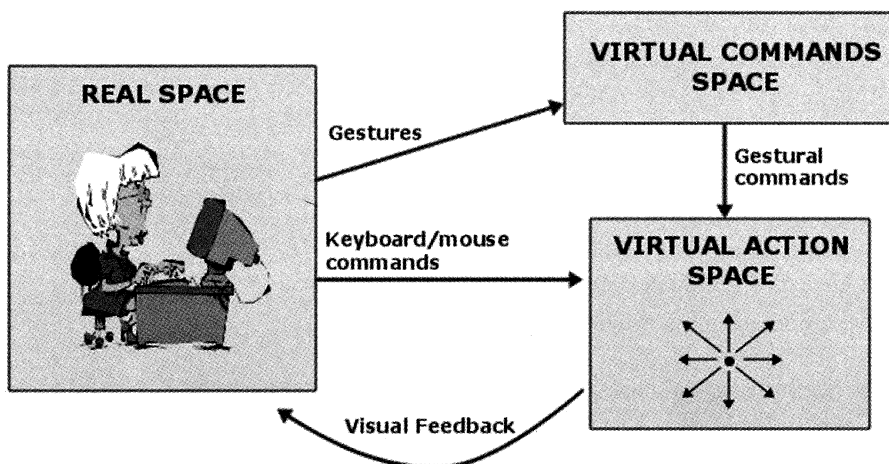

Figure 7. The DELE interaction model.

Our multi-modal interaction paradigm allows not only keyboard and mouse commands, but also web-cam captured gestures. This splits the virtual space of interaction into two parts: a Virtual Commands Space, where gestures are interpreted and mapped to commands, and a Virtual Action Space to execute commands. Such a division is needed as each Virtual Space represents a different GUI execution mode: for example, when the user's hands are recognized by the web-cam, the GUI may enter a graphical menu specialized for gesture commands, thus letting the user understand this interaction mode switch. The Virtual Action Space is an environment where visual and bodily-related actions and events are presented as really happening. Users move, grasp objects, enter buildings, meet people, etc, receiving real-time information as in real life via the visual channel.

5.2 DELE Architectural Details

Figure 8 represents the main features of DELE, with different layers shown in different colors. Grey modules within each block represent block-specific elements, while arrows describe dependencies. An arrow goes from one module to another if the source module provides the functionalities for the target to be implemented. Arrows directed from one module to an entire block specify that each module within such block depends on the source module. The user interaction in DELE does not require special hardware. An additional software layer implements a gestural recognition module exploiting the webcam video stream acquisition. Simple gestures can be recognized to implement alternative ways to launch some general system commands, such as browsing the environment or asking on-line help. This feature seems to be important for deaf users, due to their natural gestural approach to communication.

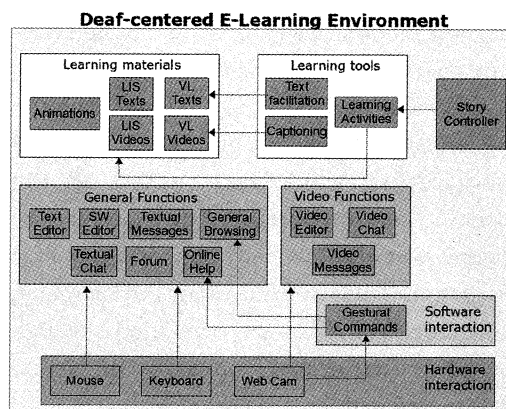

Figure 8. The DELE Architecture.

The environment implements several Verbal Language (VL) as well as Italian Sign Language (LIS) modules, addressing communicative needs of various users. LIS modules are implemented both in video streaming and in written form. For the latter to be provided, an ad hoc SignWriting (SW) editor is being developed, providing a more usable GUI than [29].

Video functions are fundamental to DELE: signing deaf users can communicate via SL through video tools, while non-signing users can use them for digital storytelling activities. User functions of DELE include: synchronous/asynchronous collaboration, textual and video chats for both one-to-one and conference communication, private messages, and a discussion forum. Learning materials use animation, VL, and LIS. Cognitive Embodiment (CE)-based text facilitation techniques enrich text materials with additional contents, viz. iconic representations of bodily and socio-cultural meanings embedded in a word. To explain a word like “into”, short videos (or animations) showing a person entering a house, a girl entering a wood or a child entering the last piece into a puzzle, can be shown on demand to infer the concept of “into”. We envisage logical, associative or game-like learning activities

(top-left module in Figure 8), and design real-time cooperative tasks (*laboratories*).

Typical in DELE is the fact that the implementation of the presentation-related architectural modules is based on the metaphor-story coupling. For example, the forum is metaphorically represented as a discussion board in the campus environment, laboratory activities are presented through avatars collaborating on tasks in virtual classrooms, etc.

6. THE DELE STORY CONTROLLER

Figure 8 shows that all the learning activities depend upon a “Story Controller” module, which is detailed in Figure 9 and maintains information on story-related structural aspects of DELE. In particular, the DELE “narrative structure” can be thought as a two-level story: the first level is represented by a sort of “global view”, while The second one is represented by the

“Personal Story” module of Figure 9. At the first level the Campus Story provides the general environment in which users can freely move between different virtual places (i.e. home, library, coffee, etc.) using avatars. Usage statistics and other information affecting the entire virtual society are collected by the system within this narrative level. Moreover, a Social Culture is created. As each narration participates in culture creation [10], a general view of common beliefs and of the results of exchanging different opinions must be maintained. General (common) beliefs can derive from knowledge acquired in learning activities, as well as from discussions among students and with the tutor. The Social Culture information can be also used to improve the user’s motivation to actively participate in the virtual society: for example, users can challenge beliefs which are commonly accepted by the majority by taking part in discussions.

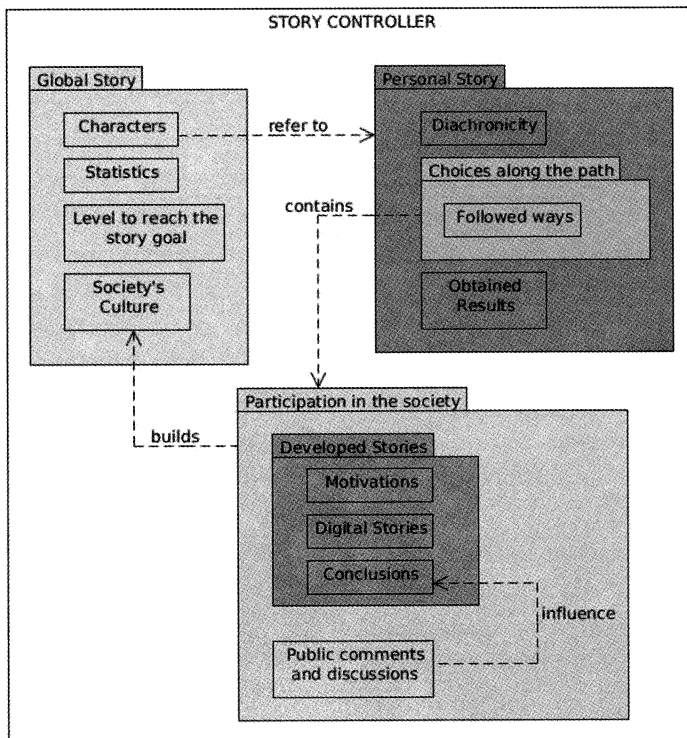

Figure 9. The Story Controller module.

At the second narrative level, the “Personal Story” module manages all information about the users-specific learning stories. Several other modules are connected to this: “Obtained Results” sums up the current user level and “Choices along the path” manages data on performed choices and actions. “Followed paths” stores pointers to the user learning activities. “Participation in the society” refers to intentional interaction with other users and is the main source of the virtual society’s culture. The Digital Storytelling project and McDrury’s and Alterio’s model [13] are implemented, taking into account users’ motivations, produced stories and conclusions of tutored public discussions. Users’ stories can deal with topics related to learning contents, but also with their personal interpretations and expansions. Conclusions are next processed in order to develop a current society’s culture, for example presented as news published on the campus main square.

Finally, the Diachronicity module specifies the chronological structure of each Personal Story. Specific SLAs provide a representation of university exams and other learning sub-environments which are organized as strongly structured stories generated by the Diachronicity module. In this context the path is generated in order to control the diachronic process of the student’s learning. In fact, every student’s Personal Story represents a learning process, shown as a path along several learning stages (Figure 10).

In every moment, a student is in exactly one location but, as in a real path, past choices and possible future ones are available. Every node along the path represents either a learning

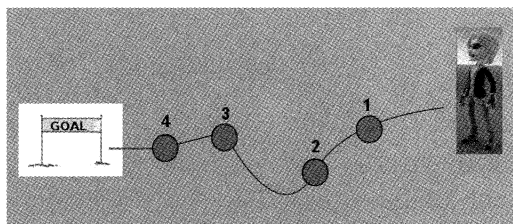

Figure 10. The Personal Story as a path.

activity or a sub-story. Although every learning process can be represented as a linear path from a starting place to a final goal, arbitrary path topologies are allowed. For example, a “star” topology can represent a sub-story (Figure 11).

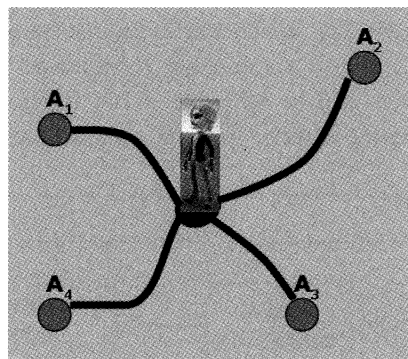

Figure 11. A “star story”.

It is worth mentioning that Figures 10 and 11 provide a qualitative graphical view of learning paths as they will be visualized by users. In order to provide a formal model of the Story Controller, a more detailed structural description of learning paths follows.

6.1 Leaf-Nodes and Story-Paths

We define two different kinds of learning node:

- A learning activity node, called Leaf-Node (LN). A state machine M_{LN} can be used to model such kind of node, which is composed of a learning activity and its assessment (Figure 12).
- A Story-Path (SP): a generic path with an arbitrary topological structure. The state machine MM_{SP} can be used to describe all the possible learning paths and choices to be presented to users (Figure 13). MM_{SP} provides a meta-model of SP, hence a state machine M_{SP} is generated as an instance of MM_{SP} in order to model a SP.

Either LN or sub-stories (recursively nested SPs) can be found as possible nodes in each SP. Figure 13 shows a separation

between state machine structure and, consequently, protocol nodes (i.e. nodes that define the story path) and LNs. Entering a SP, a choice between “permitted” nodes (e.g. the first node in a linear path) is given to the user until all nodes have been visited. This choice can take the user either to a LN (called LN_{curr} in Figure 13), which represents an instance of M_{LN} , or to a sub-story, represented as a recursive call to SP_{curr} . If a LN is chosen, a learning activity and its assessment are

presented to the user. When the user returns to a non-finished sub-story, the global story context is recreated thanks to the *deep-history* state machine pseudo-state.

The LN assessment affects the system behavior: when the user obtains a weak or insufficient evaluation, the possibility to return to the last visited node is offered, as well as a visualization of in-depth activities for that node. If an insufficient evaluation is obtained, next nodes in the ordered path are shown as

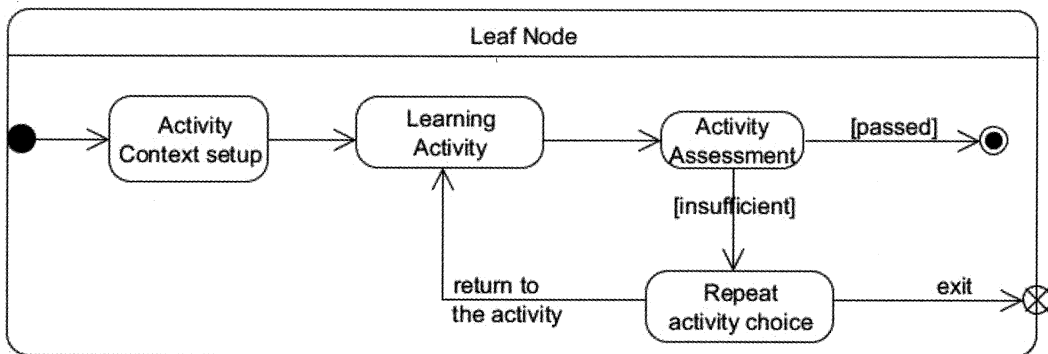

Figure 12. A LN model using state machines.

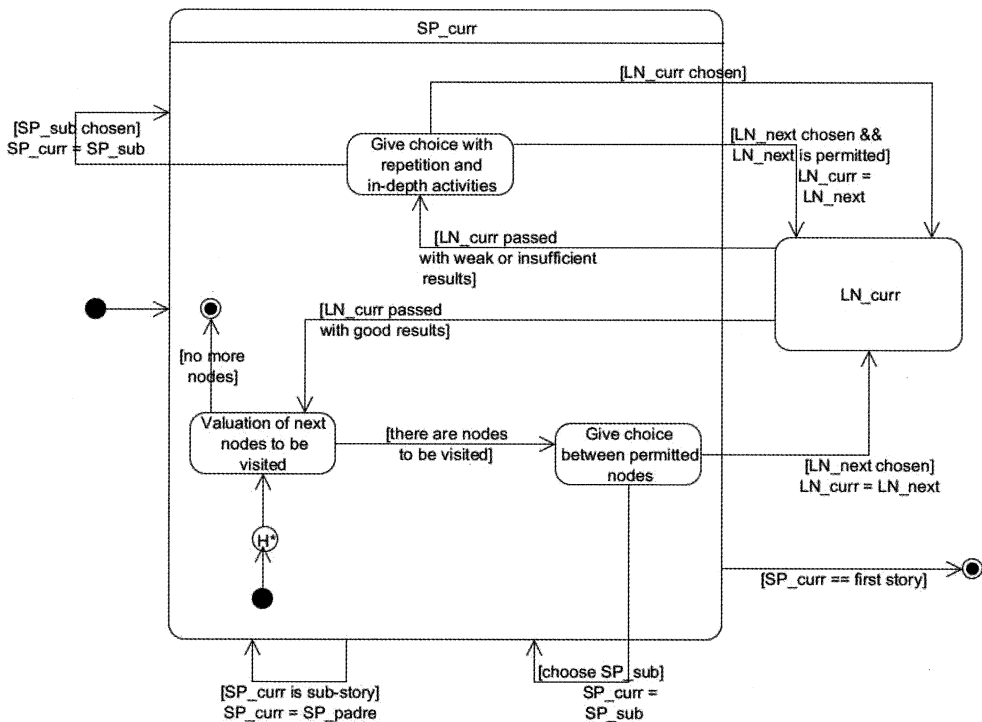

Figure 13. A meta-model of all possible SPs using state machines.

not permitted to the user. Finally, in-depth activities are not presented within the main path as possible choices when a positive assessment is obtained, even though they can be shown on demand.

In order to clarify this point, let us describe an high-level scenario. Suppose that the SP shown in Figure 14 is being visited by the user.

Hence, at the beginning, only the way

going to A_1 is marked as “active”, while all the others are not allowed. A_1 might be passed with a weak or insufficient assessment, as shown in Figure 15. If A_1 has been passed with weak results (Figure 15-a), the way to A_2 is activated, but the way to A_1 is still active too, and all its in-depth activities are exposed. On the contrary, if A_1 hasn’t been passed (Figure 15-b), in-depth activities for A_1 are shown, but the way to A_2 is left forbidden.

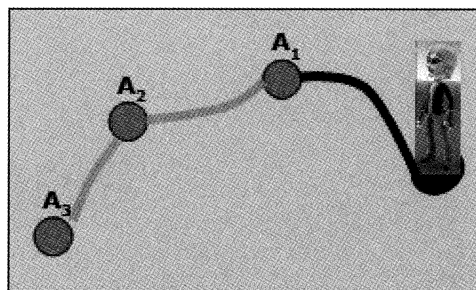
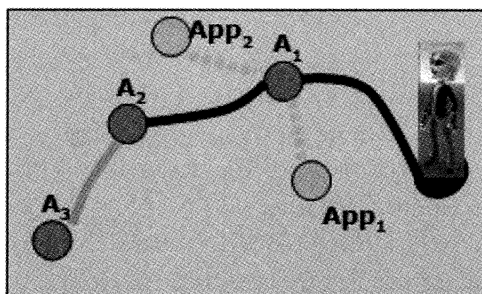
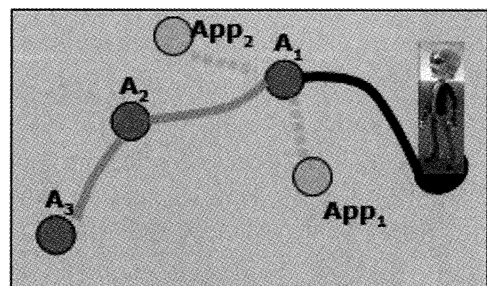

Figure 14. A story with only one allowed node.



(a)



(b)

Figure 15. The in-depth activities management: (a) A_1 has been passed with weak results; (b) A_1 hasn’t been passed (insufficient result).

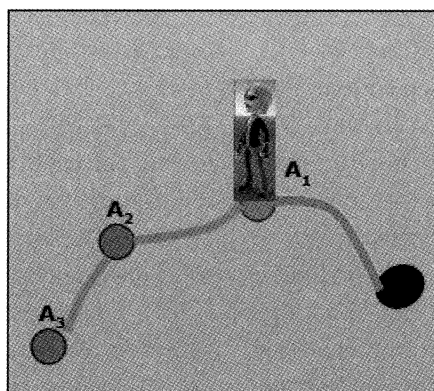

Figure 16. A scenario path when A_1 has been passed with good results.

reference called LN_{root} in Figure 17; from every node of a CSN it is always possible to visit another CSN node, to move backwards of one hop, or to return to the CSN root.

To provide a clearer reading, in the following, a state called “Contextual/Semantic Neighbourhood” (or “CSN”) will be shown to reference the part extending the original meta-model described in Figure 17.

As stated above, LN_{curr} is recognized as the present CSN root, thus the CSN exploration always ends with a transition back to this node. The LNs belonging to the CSN, in general, do not match LNs defined for in M_{sp} ; in fact the choice order and topological structure of the main SP is not followed in CSNs, and arbitrary browsing leaps are introduced. Once entered a CSN, users can go deeper and deeper into it, thus theoretical bounds to the CSN depth are not given. Nevertheless a pointer to the CSN root is stored in order to keep browsing easiness and coherence, and allow an “emergency exit” if the user gets lost.

6.3 CSN and Context Information

Figures 12 and 17 often refer to the “context” of a LN. In fact, each LN relies on the present *context* of the user’s learning path. Let us describe in more detail such concept by using a metaphor that we called “Present instantiation of memories”.

Imagine a book. We could describe written characters as a code used to store a set of concepts. When we read, we use that code to recreate such concepts in our minds and understand the book story, but when we are recreating concepts in our mind, they do not always contribute in the same way to the resulting cognitive/emotional structure. Since the present context affects the general “quality” of concepts, reading a book in two very different situations does not lead to the same emotions felt, even though the mere textual component (lexical and conceptual) of the book is the same.

Hence the act of “rebuilding” a concept in memory can be described as a conceptual blend, where the input domains are the concepts to be instantiated and the present context. This scenario is depicted in Figure 18.

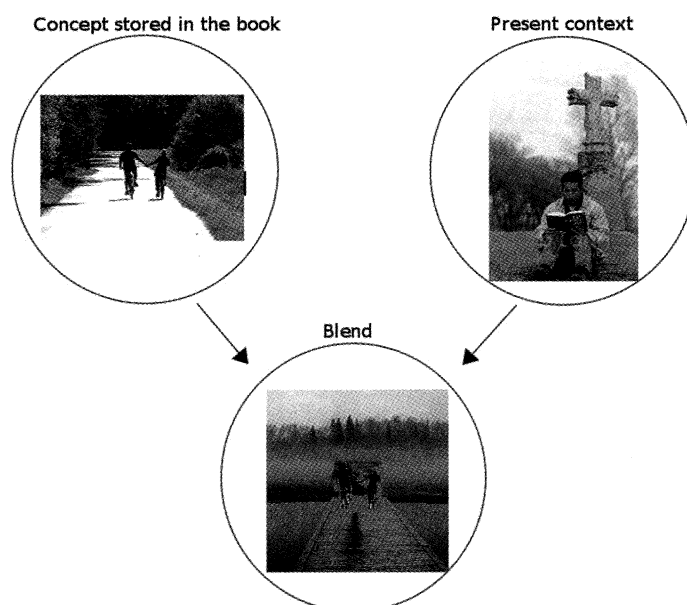

Figure 18. Instantiation of concepts in present context.

Although Figure 18 shows a rather extreme example, it is useful for understanding our idea: the return of the concept to be instantiated is modified through the conceptual blend, taking into account the present context; in this way a qualitative, but non structural, change is applied to the concept itself.

This metaphor can also be used for our CSN: LN_{curr} represents the current context of the user, applied to the related CSN nodes. In particular, the context of LN_{curr} must be preserved when the user chooses to visit a LN_{sem_near} which is semantically near to LN_{curr} . For example, if LN_{curr} contains an activity about substantives and LN_{sem_near} contains an activity about articles, the system could present LN_{sem_near} changing all substantives appearing in its content by default with those used in LN_{curr} ; as another example, the general graphical appearance (background, font, ...) of LN_{curr} could be applied to LN_{sem_near} , ecc.

To make the LN structure clearer, both a set of structural elements (not context-sensitive) and a set of Context-Sensitive Elements (CSEs) must be defined for each LN, and the "Activity Context setup" state (shown in Figures 12 and 17) manages the context setup for LN_{curr} . For example, the list of substantives of a phrase, the background image of a page, the fonts type used are all possible CSEs. In particular, the default CSEs for each LN are loaded when the user follows the "normal" path, while the LN_{root} 's CSEs are loaded during CSN exploration.

How can we actually implement CSNs? A static structure is stored in order to keep the entire implementation model simple. A set of *semantic attributes*, stored into a shared database, are defined for each LN. Such attributes define a simple semantic description of the activity. For example, a SUBSTANTIVES attribute might be defined for the activity about substantives described above. Then, a set of substantives found within the activity can

represent an activity's CSE, that can be associated to the attribute. Whenever the user visits a node (LN_{curr}), a request to the server is sent in order to find every node which declared any subset of the LN_{curr} 's CSEs: such nodes will make up the LN_{curr} 's neighbourhood. Moreover, attributes also provide the definition of the context. In fact, when an attribute is declared by a LN, an association between this attribute and a subset of the LN's CSEs must be provided. In this way, if LN_{curr} represents the current context and LN_{sem_near} belongs to LN_{curr} 's CSN, e.g. because both LN_{curr} and LN_{sem_near} share an attribute called a_1 , LN_{curr} 's context can be applied to LN_{sem_near} as follows: every LN_{sem_near} 's CSEs associated with a_1 are replaced with the LN_{curr} 's CSEs associated with the same attribute.

A further elaboration of the simple example above will clarify this point. Suppose that an exercise about articles represents the LN_{sem_near} 's activity. We can imagine the exercise as follows:

__ *child* eats __ *sandwich*.

The user can pass this activity by just replacing the blank spaces with a possible right article (e.g. "The", "a"). Substantives within the phrase are a LN_{sem_near} 's CSE (i.e. "child", "sandwich"). In the LN_{sem_near} definition an attribute called SUBSTANTIVES has been defined and the substantives contained in LN_{sem_near} 's exercise phrase have been associated to such attribute (S1 = child, S2 = sandwich). Suppose that the user passes the LN_{sem_near} 's activity and then enters LN_{curr} . This node contains an activity about substantives in which a sentence (containing some substantives) is shown to the user and he/she has to choose an image to be matched with each substantive. Suppose to have the following sentence:

The dog bites its bone.

A LN_{curr} 's CSE are the list of substantives within the phrase (i.e. "dog", "bone") as in the precedent activity. The SUBSTANTIVES attribute is declared also by LN_{curr} , with a self-explanatory association (i.e. $S_1 = \text{dog}$, $S_2 = \text{bone}$). If the exercise about articles is entered as a neighbour of LN_{curr} , the context defined by LN_{curr} is applied to this LN_{sem_near} : in order to accomplish this, the shared attributes between both LNs are taken (only SUBSTANTIVES in this case) and, for each i -th LN_{sem_near} 's CSE associated with the attribute, the i -th LN_{curr} 's CSE associated with the same attribute is replaced to it. In this case, the list of substantives within LN_{sem_near} is replaced with the list of substantives of LN_{curr} . Thus, the LN_{sem_near} 's (articles) activity is shown to the user as follows:

__ dog eats __ bone.

This is clearly an extremely simplified example, but arbitrary contexts can be defined using the same mechanism.

Three different kinds of materials can be used to define a number of different kinds of CSNs:

1. *Recommended In-Depth Activity* (RIDA): material that is a-priori chosen by the tutor, who statically defines attributes in order to semantically connect activities with each other.
2. *Past Correlated Activity* (PCA): material coming from the user's interaction past history that is semantically correlated with the current activity. It is dynamically calculated as the user proceeds along the learning path. In particular, the first time a user enters a node (LN_{curr}), each node belonging to the user's interaction history is analysed in order to test its semantic correlation with LN_{curr} .
3. *Personal In-Depth Activity* (PIDA): material stored by the user due to personal interest.

Customized learning paths can be created with this kind of materials. Custom tags can also be defined by the user to semantically connect activities.

In the rest of the paper, we will refer to CSN based on RIDA materials as "tutor-defined CSNs", and to PCA/PIDA-based CSNs as "user-defined CSNs".

Finally, each LN can be associated with resources other than CSN activities: for example, a list of links to learning materials stored in the Campus society and semantically related to the current activity are presented, as well as a list of users which passed the current activity with good results. These users could be contacted for consults and information sharing.

6.4 Laboratories

Collaborative activities, called laboratories, need particular care. Here the information about the set of involved users has to be maintained, but user CSNs must be distinguished from tutor ones. In fact, since the past/preferred activities are generally different for each user, different user-defined CSNs are to be shown to each one. A high-level view of this structure is presented in Figure 19.

Two parallel SPs are shown, each one defining its own flow of execution (thick arrows) driving the users through several sub-stories. Each sub-story has an arbitrary topological structure and contains several LNs. Only two levels of browsing depth are shown in Figure 19, (i.e. starting from the main SP, users reach one sub-story and then return back to the main SP), but there's no theoretical bound to this, as demonstrated in the MM_{SP} meta-model (see Figures 18). The user-defined CSN nodes are accessed through the dotted arrows. The laboratory activity is a LN itself, which belongs to both paths. Since the personal interaction history changes among users, in

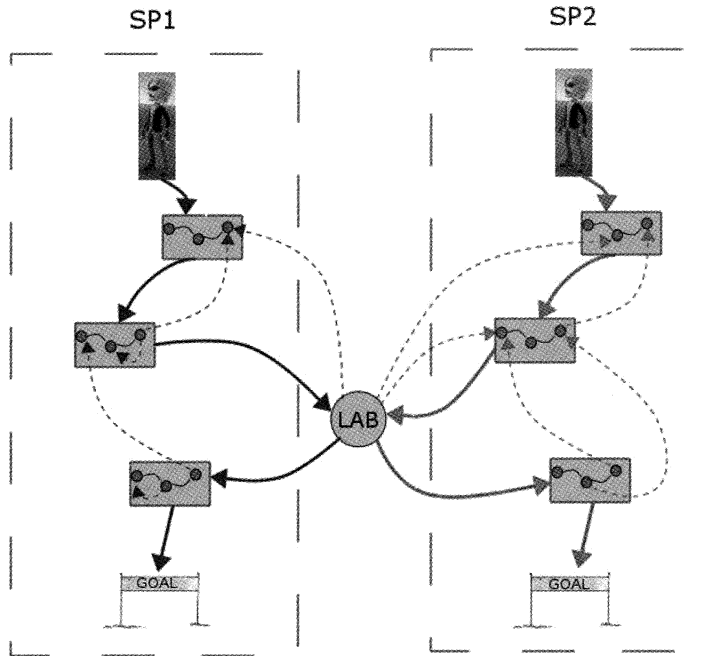

Figure 19. A scheme of two possible stories with a common collaborative activity (laboratory).

general different paths are defined for different SPs and different users.

Therefore, two distinct sets of links to the user-defined CSN nodes are provided for the two users from the laboratory LN, and they have been drawn using two different colors in Figure 19.

A different statecharts-based model is needed for laboratories. In fact, information about several users must be maintained, where each user has both a personal and a shared work to be done. Figure 20 shows the MM_{LAB} meta-model used to describe the possible kinds of laboratories.

Laboratory work is divided into two parts: an asynchronous personal work and a synchronous shared one. Parallel asynchronous regions within the “Personal Work” state model users’ personal activities. Users can freely join and exit the laboratory and a possible exit point is reached when all users exit before all the work has been done. The *deep history* pseudo-state re-establishes the lab

global state when the work is restarted. Moreover, CSN nodes can be reached: from personal work regions distinct user-defined CSNs are accessible as well as a unique tutor-defined CSN.

In particular, even though the same tutor-defined CSN nodes are shown for all users, actually different users access different instances of such nodes. A state with mandatory synchronous access models the shared work. From their own personal works, users can enter the shared work only if all participants are available.

The “shared work needs to be done” condition is true whenever the shared work is not completed. In any case the user can decide to enter the shared work even when personal work has not been done. A message is always sent to all participants asking them to enter the shared work when some users request it. In this way synchronization is set up among all participants. A lack of synchronization can occur if some of the users cannot attend to

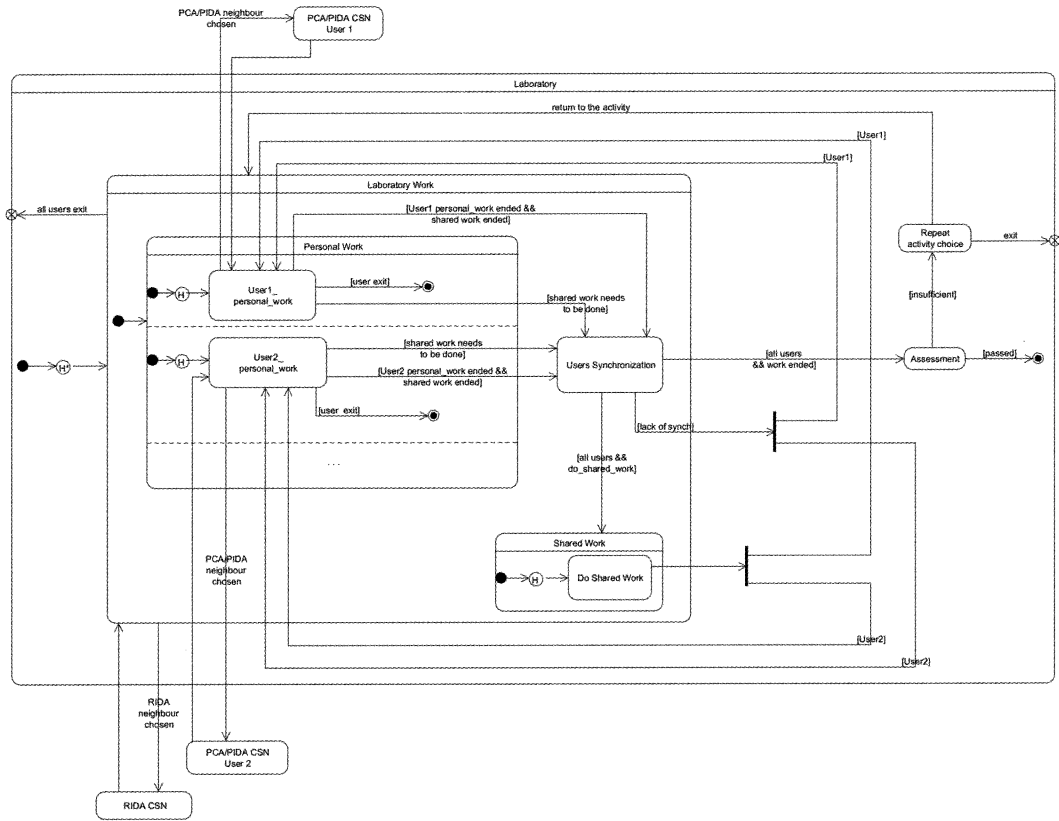

Figure 20. The meta-model for all the possible laboratories.

the shared work when the request is sent. In this case the other users waiting on the “Users Synchronization” state can go back to their personal works. Since both the personal work regions and the shared work state can be accessed an arbitrary number of times within a single laboratory execution, a *shallow history* pseudo-state has been included in such machines in order to recreate the right contexts. When users synchronization is obtained and the shared work state is accessed, users can exit from this state at any time, going back to their personal works. Such loop can be executed until all work, both personal and shared, has been finished. An assessment is obtained when this condition occurs and, if an insufficient result is achieved, users can

choose either to return back to the lab activity or to exit.

In the MM_{LAB} meta-model we added a piece of custom notation to overcome the limitations of the concrete syntax of state machines: the presence of an arbitrary number of parallel regions within the “Personal Work” state is expressed with the additional notation (“ . . .”). Following [31], the abstract syntax model depicted in Figure 21 provides a scheme to formally define the additional notation.

More precisely, a state machine with two orthogonal regions is defined. Then, the colored block shows that an arbitrary number (vars $e \geq 0$) of additional regions can be added to the machine.

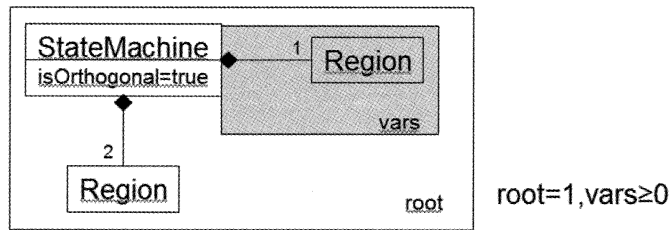

Figure 21. The abstract syntax model to describe the “Personal Work” state of Figure 20.

6.5 Story Controller Architectural Details

Summing up, the following information needs to be stored in each instance of a specific node, which may be visited by single different users at any time:

- Information concerning a Leaf-Node instance (LN_infos):
 - father SP;
 - structural elements (non context-sensitive);
 - Context-Sensitive Elements (CSEs);
 - semantical attributes;
 - list of semantically near LNs (RIDA, PCA, PIDA);
 - Campus learning materials which can be useful for the activity;
 - assessment criteria;
 - flag indicating if the activity is a laboratory.

In this case two additional pieces of information are needed:

 - list of other participants. The group of participants are usually established between users themselves;
 - shared resources for the laboratory;
 - flag indicating if the activity has been passed or not;
 - activity assessment.
- Informations concerning a Story-Path instance (SP_infos):
 - SP nodes set. Each node can be either a LN or a sub-story;
 - SP's difficulty;
 - topological structure;
 - current stage within the SP;
 - possible next choices;
 - next stage suggested choice;

- list of user which passed this SP with good results;
- SP finished or not;
- general assessment of SP.
- General informations:
 - chronological list of all activities in the user's interaction history.

As stated above, the main data structures are statically stored from the SPs descriptions which are designed by a tutor. In this way, once the SPs descriptions as well as the tutor CSN nodes are provided, the needed MM_{SP} instances are generated by the Story Controller. Then, Campus resources, user CSNs and on-line users lists are dynamically computed and presented to the user. About contexts building, all CSN nodes for a LN are obtained through database queries by comparing attributes information.

In order to limit transactions to/from the server, SPs execution is mainly performed within clients, while communication with the server is started only in particular cases: information about the next stage on the path are needed at the beginning of an activity and a sub-story; information are sent by the client only at the end of sub-stories. This leaves Leaf-Nodes execution management entirely within clients. Figure 22 shows this behavior.

SP_infos described above are sent by the server once the sub-story information is requested. In the same way, LN_infos are requested from within each sub-story. LNs are executed on the client and local data are

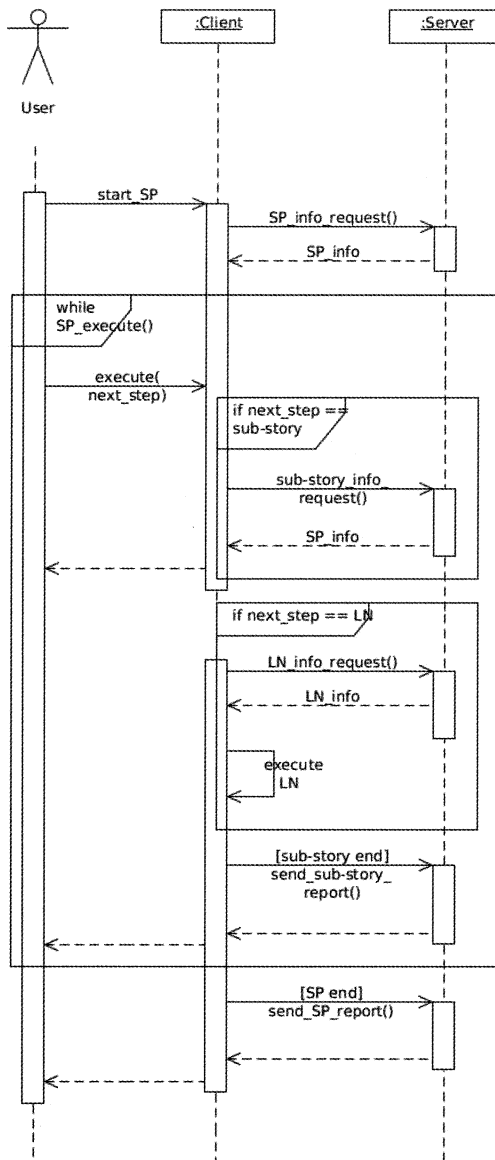

Figure 22. client-server dialog sequence.

stored when each LN belonging to the same sub-story is finished. Finally, when the user reaches the end of a SP, the complete report describing the visited LNs list and obtained results for that SP is sent to the server.

6.6 A Story Scenario

Finally, a meta-model of the system interface during a SP execution is shown in Figure 23. Notice that, in this case, a node refers to a screen element and not to a specific

activity.

A global view of SP path is shown to the user on the first screen. Here all SP stages (i.e. both LNs and sub-stories) are presented, suggesting the next one(s) to be visited. As stated above, such suggestions are dynamically computed by the system during execution, following the imposed order of nodes and activities assessments. A recursive call to the starting state is shown in Figure 23 to represent the choice of a sub-story, and a similar behavior is presented when a sub-story is left. When a learning activity (i.e. a LN) is entered, the activity itself is presented on the main part of the screen, while CSN nodes, users and resources links related to the activity are simultaneously shown.

Parallel regions within the “GUI-Leaf-Node LN_k” state manage all parts of graphics, hence links could be selected at any moment by users in an asynchronous manner with respect to the activity flow of execution. GUI’s elements that have to be shown at each LN execution are represented by such parallel machines.

Moreover, LN_j represents a user/tutor-defined CSN node. As already shown in Figure 17, no depth bounds are fixed to CSNs, therefore users can go deeper and deeper into it. From within each node of a CSN, users can choose to go back one hop or to return to the CSN root. Finally, a LN_j representing an in-depth activity for LN_k can be accessed from the main screen of the SP.

7. CONCLUSIONS

We suggest storytelling as the basis for the development of a Deaf-centered E-Learning Environment, within the framework defined by Conceptual Metaphors and Embodied Cognition. The present work aims to underline how such a set of conceptual tools, which are usually singularly exploited in different domains, can be synergically combined to design a novel educational strategy. Following this, we started to develop

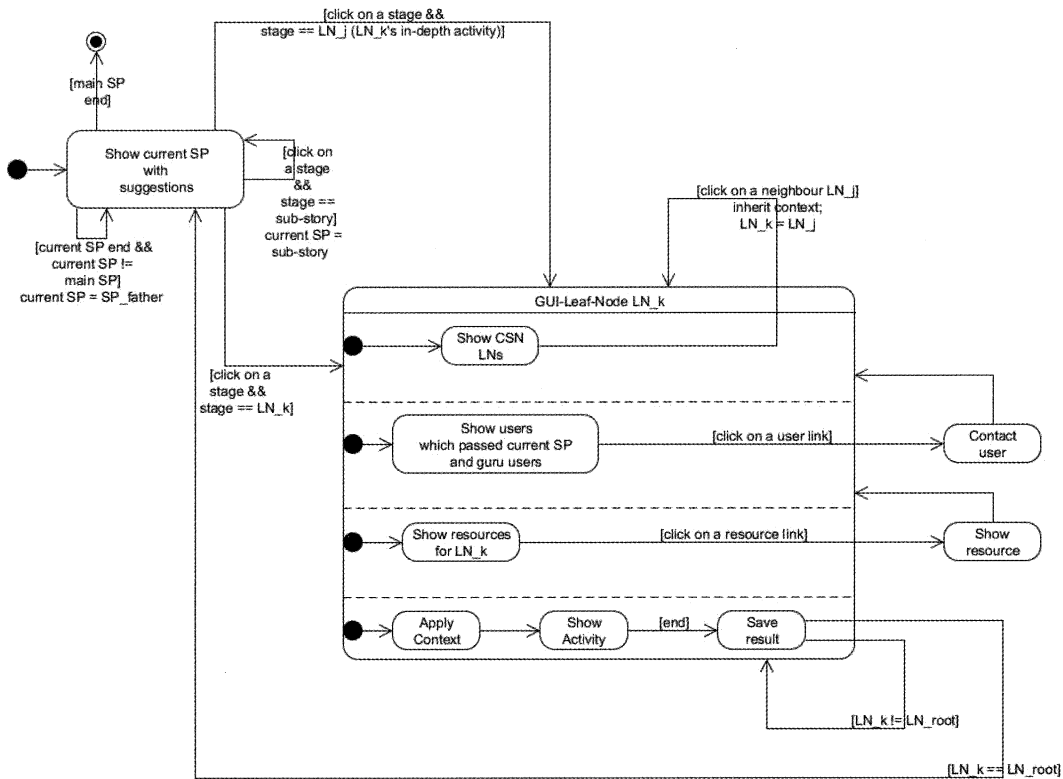

Figure 23. A Meta-model for a Typical Scenario of SP Execution.

ACKNOWLEDGMENTS

Work partially funded by Italian Ministry of Education and Research (MIUR-FIRB), VISEL-RBNE074T5L E-learning, Deafness and Written Language (2009-2012), see <http://www.visel.cnr.it>.

REFERENCES

[1] Paulos J.A., Innumeracy-mathematical illiteracy and its consequences, First Hill and Wang ed., 1988.
 [2] Math anxiety, <http://www.counseling.txstate.edu/resources/showoverview/bro/math.html>
 [3] Literacy and national reading statistics, teaching reading: educational cyberplayground, <http://www.edu-cyberpg.com/Literacy/stats.asp>
 [4] Lettura di libri in Italia, [http://culturaincifre.](http://culturaincifre.istat.it/sito/libri/letturalibrinitalia.pdf)

[istat.it/sito/libri/letturalibrinitalia.pdf](http://culturaincifre.istat.it/sito/libri/letturalibrinitalia.pdf)
 [5] Plato, The Symposium, Greek text with commentary by Kenneth Dover. Cambridge: Cambridge University Press., 1980.
 [6] Plato, Theaetetus <<http://onlinebooks.library.upenn.edu/webbin/gutbook/lookup?num=1726>>.
 [7] Jean-Jacques Rousseau, Emile, or On Education. Trans. Allan Bloom. New York: Basic Books., 1979.
 [8] Piaget J., The Psychology of Intelligence. New York: Routledge., 1950.
 [9] Vygotskij L., et al., Mind in society. Harvard University Press., 1978.
 [10] Bruner J.S., The Narrative Construction of Reality. Critical Inquiry, 1991; 18(1): 1-21.
 [11] Antinoro Pizzuto E., et. al., Language

- Resources and Visual Communication in a Deaf-Centered Multimodal E-Learning Environment: Issues to be Addressed. Proc. of 7-th Int. Conf. on Language Resources and Evaluation LREC, 2010.
- [12] McKillop C., Storytelling grows up: using storytelling as a reflective tool in higher education, Proc. of Scottish Educational Research Association conference, SERA, 2005: 24-26th November.
- [13] McDrury J., Alterio M., Learning Through Storytelling in Higher Education: Using Reflection & Experience to Improve Learning. Dunmore Press., 2002.
- [14] Center for Digital Storytelling, <<http://www.storycenter.org/>>
- [15] The educational use of Digital Storytelling, University of Huston. <<http://digitalstorytelling.coe.uh.edu/>>
- [16] Rudnicki A., et al., The Buzz Continues.. The Diffusion of Digital Storytelling across disciplines and colleges at the University of Houston, In C. Crawford et al. (Eds.), Proc. of Soc. for Inf. Tech. & Teacher Ed. Int. Conf. Chesapeake, 2006; 717-723.
- [17] Imaz M., Benyon D., Designing with blends, MIT Press., 2007.
- [18] Lakoff G. and Johnson M., Metaphor We Live By. University of Chicago Press., 1980.
- [19] Johnson M., The meaning of the body, University of Chicago Press., 2007.
- [20] Lakoff G., The Contemporary Theory of Metaphor, in E. Ortony (curated by) Metaphor and Thought, Cambridge University Press., 1992.
- [21] Lakoff G., Núñez R. E.(2000). Where Mathematics comes from, Basic Books Ed.
- [22] Rohrer T., Understanding through the body: fMRI and ERP Studies of Metaphoric and Literal Language. 7th Int. Cognitive Linguistics Association conf., 2001.
- [23] Hurtienne J., Stözel C., Sturm C., Maus A., Rötting M., Langdon P.M., and Clarkson P.J., Physical gestures for abstract concepts: inclusive design with primary metaphors. In Interacting with Computers, Special Issue on Inclusion and Interaction: Designing Interaction for Inclusive Populations., 2010; **22(6)**: 475-484.
- [24] Lakoff G., Espenson J., Goldberg A. and Schwartz A., Master Metaphor List, second ed. <<http://araw.mede.uic.edu/~alansz/metaphor/METAPHORLIST.pdf>>, 1991.
- [25] Hurtienne J., Stözel C., Weber K., Sad is heavy and happy is light: population stereotypes of tangible object attributes. In Proceedings of the 3rd International Conference on Tangible and Embedded Interaction (TEI '09): 2009.
- [26] Apple Human Interface Guidelines, <<http://developer.apple.com/mac/library/documentation/userexperience/conceptual/applehiguideines/XHIGIntro/XHIGIntro.html>>
- [27] Camilleri V. and Montebello M., Social E-SPACES; socio-collaborative spaces within the virtual world ecosystem. Proc. of 7-th Int. Conf. on Language Resources and Evaluation, LREC, 2010.
- [28] De Marsico et. al., A proposal toward the development of accessible e-learning content by human involvement. In Universal Access in the Information Society, 2006; **5(2)**: 2006.
- [29] Sign Writing site, <<http://www.signwriting.org/>>
- [30] BBC Learning English, <<http://www.bbc.co.uk/worldservice/learningenglish/>>
- [31] Bottoni P., Guerra E. and de Lara E., Enforced generative patterns for the specification of the syntax and semantics of visual languages. In Journal of Visual Languages and Computing, 2008; **19(4)**: 429-455.